

**Problem statement** A square and a circle are placed so that the circle is outside the square and tangent to a side of the square. The sum of the length of one side of the square and the circle's diameter is 12 feet, as shown. Suppose the length of one side of the square is  $x$  feet.

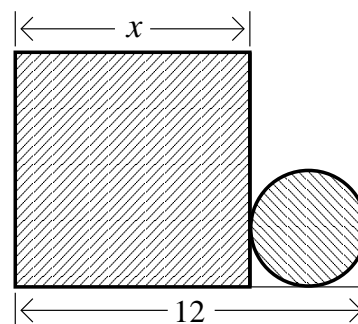

a) Write a formula for  $f(x)$ , the sum of the total area of the square and the circle. What is the domain of this function when used to describe this problem? (The domain should be related to the problem statement.) Sketch a graph of  $f(x)$  on its domain.

b) Suppose that the object (square or circle) with larger area is painted red, and the object (square or circle) with smaller area is painted green. The cost of red paint to cover 1 square foot is \$4, and the cost of green paint to cover 1 square foot is \$10. Let  $g(x)$  be the function which gives the cost of painting the squares. Describe the function  $g(x)$ . Sketch a graph of  $g(x)$  on its domain.

**Hint** Read the question *carefully*. The answer will be a piecewise-defined function. A complete answer should give all relevant information

c) Where is the function  $g(x)$  continuous? Where is it differentiable? Which value of  $x$  gives the least cost?